

## Single-Chip Wavetable Music Synthesizer

### Features

- Single low-cost device includes MIDI controller, synthesis engine, effects processing, RAM, and sample ROM
- General MIDI (GM) compliant
- 32-note polyphony at 44.1kHz rate
- Independent reverb and chorus levels for each MIDI channel
- +3.3V supply, +5V tolerant inputs
- Fully static power-down capability
- Simple to design in - Serial MIDI in, Stereo digital audio out
- Digital audio output directly Interfaces with the CS4236B/37B/38B and CS4333

### General Description

The CS9236 is a complete General MIDI wavetable music synthesizer on a single integrated circuit. The MIDI interpreter, synthesis engine, effects processing, and all RAM and ROM memories (including the wavetable sample ROM) are included on-chip. This all-digital device receives a standard serial MIDI data stream, and outputs a stereo 16-bit digital audio stream at 44.1kHz. The CS9236 digital audio output is directly compatible with the Crystal CS4236B/37B/38B multimedia CODECs, and with the CS4333 DAC.

The CS9236 features a high quality General MIDI sample set including 128 melodic instruments and 47 percussion sounds. The synthesis engine is capable of generating up to 32 simultaneous notes. Digital reverb and chorusing effects are included on-chip.

The CS9236 is the ideal low-cost General MIDI synthesizer solution for a number of applications, including multimedia PCs, game machines, karaoke, and low-cost musical instruments and MIDI sound modules.

### ORDERING INFORMATION

CS9236-CL	0° to 70°C	28-pin PLCC
CS9236-CQ	0° to 70°C	44-pin TQFP

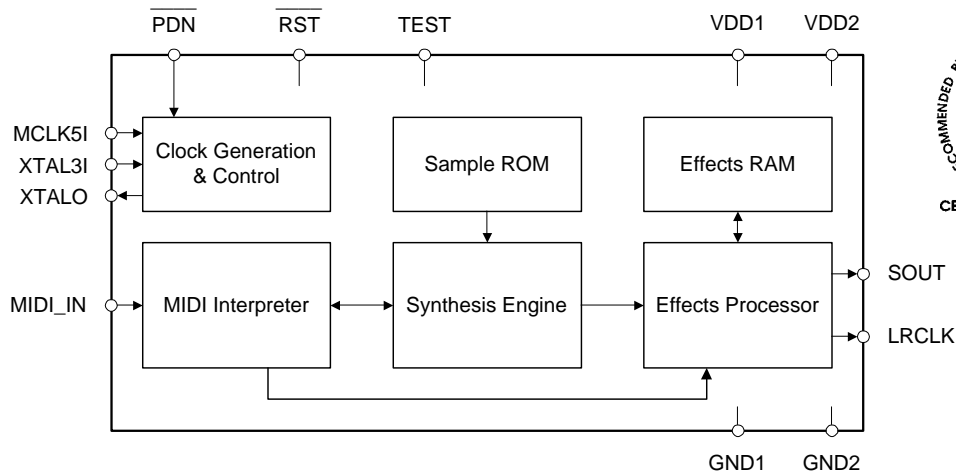

### Preliminary Product Information

This document contains information for a new product. Crystal Semiconductor reserves the right to modify this product without notice.

**TABLE OF CONTENTS**

<b>RECOMMENDED OPERATING CONDITIONS</b> .....	<b>4</b>
<b>SWITCHING CHARACTERISTICS</b> .....	<b>4</b>
<b>DIGITAL CHARACTERISTICS</b> .....	<b>6</b>
<b>ABSOLUTE MAXIMUM RATINGS</b> .....	<b>6</b>
<b>GENERAL DESCRIPTION</b> .....	<b>7</b>
CS9236/CS4236B/37B/38B Typical Connections .....	7
CS9236/CS4333 Typical Connections .....	8
CS9236 Clocks and Timing Generation .....	9
Power-Down Modes .....	9
Digital Audio Interface .....	9
Reset .....	9
<b>GENERAL MIDI (GM) MELODIC INSTRUMENTS AND PERCUSSION SOUNDS</b> .....	<b>10</b>
<b>MIDI IMPLEMENTATION</b> .....	<b>13</b>
Channel Voice Messages .....	13
Control Change Messages .....	13
Registered Parameters .....	13
Channel Mode Messages .....	13
System Realtime Messages .....	14
System Exclusive Messages .....	14
Message Definitions .....	16
Channel Voice Messages .....	16
NOTE ON .....	16
NOTE OFF .....	16
PROGRAM CHANGE .....	17
CHANNEL PRESSURE (Channel Aftertouch) .....	17
PITCH BEND CHANGE .....	18
Control Change Messages .....	19
MODULATION WHEEL (CONTROLLER 1) .....	19
DATA ENTRY (CONTROLLERS 6 and 38) .....	19
VOLUME (CONTROLLER 7) .....	19
PAN (CONTROLLER 10) .....	20
EXPRESSION (CONTROLLER 11) .....	20
DAMPER PEDAL/SUSTAIN (CONTROLLER 64) .....	20
SOSTENUTO (CONTROLLER 66) .....	21
EFFECT 1 DEPTH/REVERB SEND LEVEL (CONTROLLER 91) .....	21
EFFECT 3 DEPTH/CHORUS SEND LEVEL (CONTROLLER 93) .....	21
REGISTERED PARAMETER NUMBER (RPN) (CONTROLLERS 100 and 101) .....	22
Registered Parameters .....	23
PITCH BEND SENSITIVITY (RPN 00) .....	23
FINE TUNING (RPN 01) .....	23
COARSE TUNING (RPN 02) .....	24
Channel Mode Messages .....	25
ALL SOUNDS OFF (Controller 120) .....	25
RESET ALL CONTROLLERS (Controller 121) .....	25
ALL NOTES OFF (Controller 123) .....	25
OMNI MODE OFF (Controller 124) .....	25
OMNI MODE ON (Controller 125) .....	26
MONO MODE ON (Controller 126) .....	26
POLY MODE ON (Controller 127) .....	26
System Real Time Messages .....	27

ACTIVE SENSING.....	27
SYSTEM RESET .....	27
<b>System Exclusive Messages .....</b>	<b>28</b>
ENABLE RECOGNITION OF MIDI CHANNEL PRESSURE.....	28
DISABLE RECOGNITION OF MIDI CHANNEL PRESSURE.....	28
ENABLE TEST TONE .....	29
DISABLE TEST TONE .....	29
<b>PIN DESCRIPTIONS .....</b>	<b>30</b>

**RECOMMENDED OPERATING CONDITIONS** (DGND=0V, all voltages with respect to 0V.)

Parameter	Symbol	Min	Typ	Max	Units
Power Supply	VD	3.0	3.3	3.6	V
Operating Ambient Temperature	T <sub>A</sub>	0	25	70	°C

Per JEDEC Standard No. 8-A for LVCMOS

**SWITCHING CHARACTERISTICS** (T<sub>A</sub> = 0 - 70 °C; VD = +3.3V ± .3V, outputs loaded with 30pF;

Input Levels: Logic 0 = 0V, Logic 1 = 5V) (Note 1)

Parameter	Symbol	Min	Typ	Max	Units
Input clock (CLKIN) frequency (Note 2)	f <sub>ck</sub>	16.92	16.9344	16.95	MHz
CLKIN low time	t <sub>ckl</sub>	23.6	-	-	ns
CLKIN high time	t <sub>ckh</sub>	23.6	-	-	ns
LRCLK frequency (Note 2)	f <sub>lrw</sub>	-	44.1	-	kHz
LRCLK duty cycle		47	50	53	%
SOUT delay from LRCLK rising/falling edge	t <sub>sdsk</sub>	-	-	10	ns
MIDI_IN Bit Rate (Asynchronous to MCLK5I or XTAL3I)		30937.5	31250	31562.5	bits/s
$\overline{\text{RST}}$ pulse width low	t <sub>rpw</sub>	500	-	-	ns
$\overline{\text{PDN}}$ pulse width low	t <sub>ppw</sub>	500	-	-	ns
$\overline{\text{RST}}$ high to valid MIDI input	t <sub>rdr</sub>	300	-	-	ms
$\overline{\text{PDN}}$ high to valid MIDI input	t <sub>rdp</sub>	0.15	-	-	ms

Notes: 1. XTAL3I input level is VD.

2. LRCLK frequency is equal to f<sub>ck</sub>/384. Optimum synthesized pitch and envelope characteristics will be achieved when CLKIN frequency, f<sub>ck</sub>, is equal to 16.9344 MHz (LRCLK frequency, f<sub>lrw</sub> = 44.1 kHz).

Specifications are subject to change without notice.

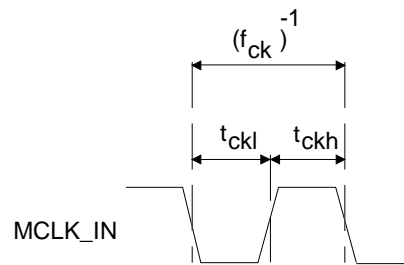

**Master Clock Timing**

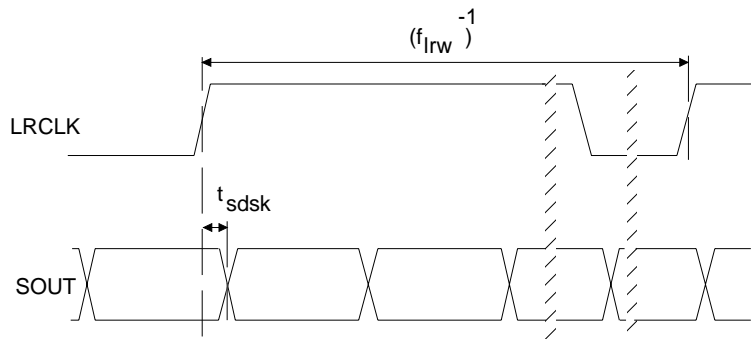

**Digital Audio Port Timing**

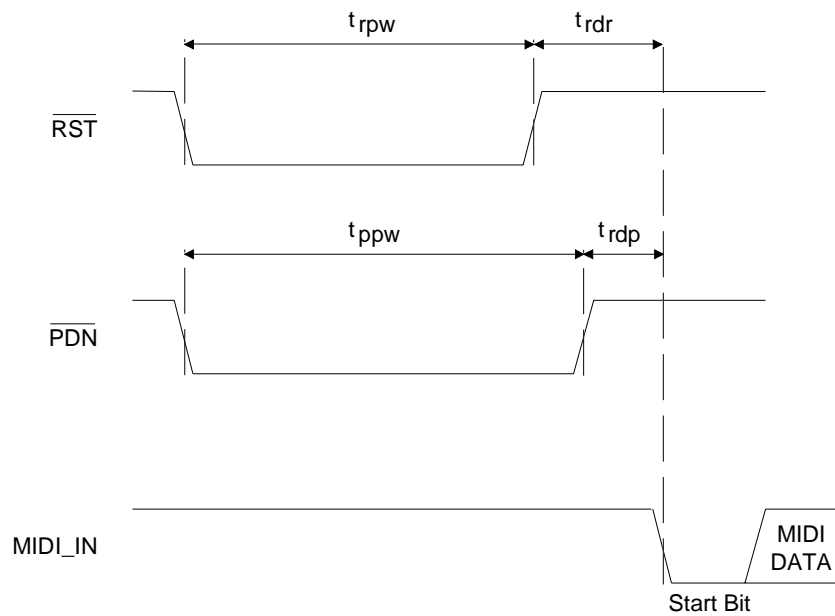

**RST/PDN Timing**

**DIGITAL CHARACTERISTICS** ( $T_A = 25\text{ }^\circ\text{C}$ ;  $V_D = +3.3\text{V}$ )

Parameter	Symbol	Min	Max	Units
High-level Input Voltage (Note 3)	$V_{IH}$	2.0	-	V
Low-level Input Voltage	$V_{IL}$	-0.3	0.8	V
High-level Output Voltage at $I_O = -100\mu\text{A}$ at $I_O = -1\text{mA}$	$V_{OH}$	$V_D - 0.3$ $V_D - 0.5$	-	V
Low-level Output Voltage at $I_O = 100\mu\text{A}$ at $I_O = 4\text{mA}$	$V_{OL}$	- -	0.3 0.5	V
Input leakage Current (Digital Inputs)		-	10	$\mu\text{A}$
Supply Current (Normal Operation)		-	150	$\text{mA}$
(Power Down with $\overline{\text{RST}}$ )		-	400	$\mu\text{A}$
(Power Down with $\overline{\text{PDN}}$ )		-	1	$\text{mA}$

Notes: 3. JEDEC Standard No. 8-A for LVCMOS, copyright Electronic Industries Association 1994, specifies  $V_D + 0.3$  max. CS9236 digital inputs are +5V tolerant.

**ABSOLUTE MAXIMUM RATINGS** ( $DGND = 0\text{V}$ , all voltages with respect to 0V)

Parameter	Symbol	Min	Max	Units
Power Supplies	$V_D$	-0.3	4.6	V
Input Current (Except Supply Pins)		-	$\pm 20$	$\text{mA}$
Digital Input Voltage		-0.3	5.25	V
Ambient Temperature (Power Applied)		-55	125	$^\circ\text{C}$
Storage Temperature		-55	125	$^\circ\text{C}$

Warning: Operation beyond these limits may result in permanent damage to the device. Normal operation is not guaranteed at these extremes.

## GENERAL DESCRIPTION

The CS9236 is a complete 32-note General MIDI music synthesizer with integral digital effects processing in a single device. This device accepts a standard serial MIDI data stream at 31.25 kbit/s and generates a stereo digital audio output data stream at 44.1 ksamples/s sampling rate. The device operates from a single 3.3VDC supply. The digital inputs to the device are 5V tolerant, allowing direct connection to parts which are powered from 5V or 3V supplies. The CS9236 has been designed to interface directly with the Crystal Semiconductor CS4236B/37B/38B Single Chip Audio Systems and with the CS4333 Stereo D/A Converter (DAC). When the CS9236 is used in conjunction with the CS4236B/37B/38B, the digital audio output from the CS9236 is input to the CS4236B/37B/38B in digital format, so no separate DAC is required. In applications which require an analog output from the CS9236, the CS4333 DAC is employed to convert the digital audio output of the CS9236 into analog format.

### CS9236/CS4236B/37B/38B Typical Connections

The CS9236 combined with the CS4236B/37B/38B provides

a complete ISA Plug-and-Play compatible sound system for multimedia PC applications. Figure 1 depicts the typical connections between the CS9236 and the CS4236B/37B/38B. In this application, the CS4236B/37B/38B 16.9344 MHz MCLK gated clock output drives the CS9236 MCLK5I input, eliminating the need for a separate quartz crystal circuit.

MIDI messages are sent from the host PC to the CS4237B over the ISA bus. The CS4236B/37B/38B provides a Plug-and-Play configurable MPU-401 UART mode-compatible ISA MIDI interface. The CS4236B/37B/38B MPU-401 UART function transmits the MIDI data received over the ISA bus to the CS9236 (and to the Joystick MIDI Out pin) in serial format. The CS9236 interprets the MIDI messages and generates the appropriate musical sounds. These sounds are output in serial digital audio format at the CS9236 SOUT pin. The digital audio output from the CS9236 is input directly into the CS4236B/37B/38B, eliminating the need for a separate DAC.

For more details on using the CS9236 with the CS4236B/37B/38B, see Application Note 92, "Configuring the CS423xB/CS9236 Wavetable Interface."

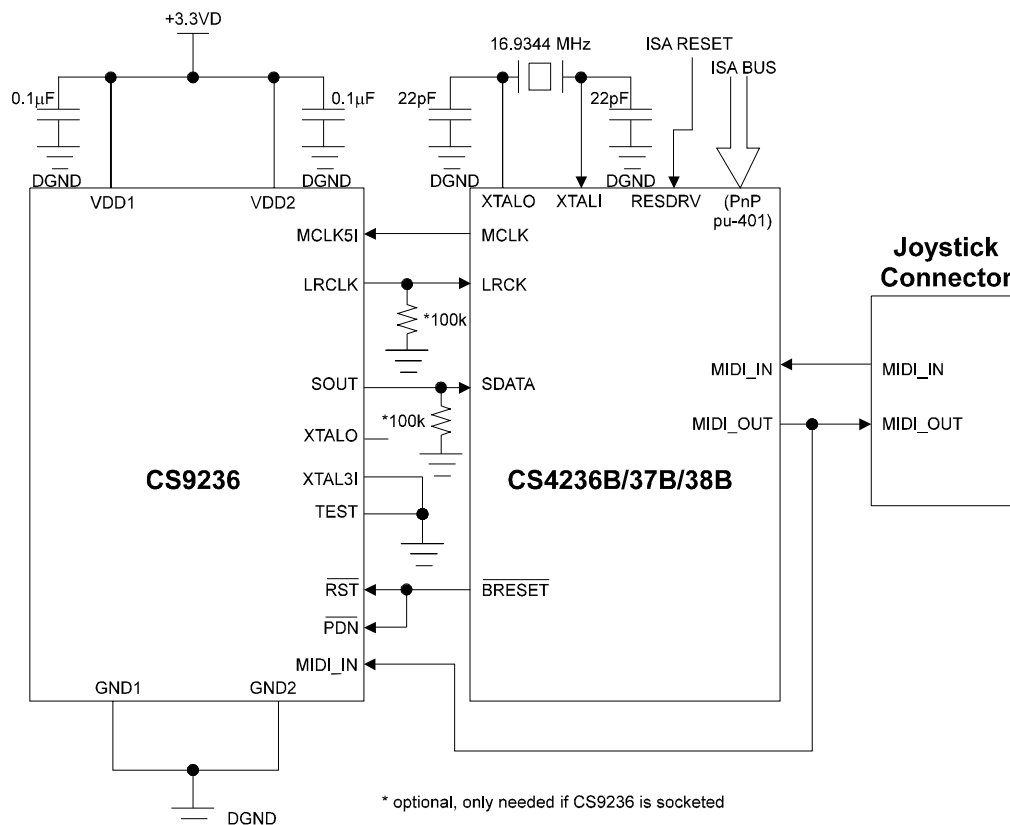

Figure 1. CS9236/CS4236B, CS4237B or CS4238B Typical Connections

## CS9236/CS4333 Typical Connections

In applications which require analog audio output from the CS9236 synthesizer, the CS4333 Stereo DAC is utilized. Figure 2 shows typical connections for a stand-alone music synthesizer application (e.g. low-cost musical keyboards, MIDI modules, game boxes). In this application the CS9236 digital audio output, SOUT, and the associated clocks, LRCLK and XTALO, are input to the CS4333. The CS4333 converts the stereo digital audio data stream into left and right analog audio outputs, LOUT and ROUT.

Note that the example shown in Figure 2 employs an R-C filter circuit to generate a reset signal which is applied to both

the CS9236  $\overline{\text{RST}}$  and  $\overline{\text{PDN}}$  inputs. In some applications it may be desirable to control one or both of these control signals dynamically.

The CS4333 clock input is driven by the CS9236 crystal oscillator output pin. The CS9236 must be placed as close as possible to the CS4333 in order to minimize the length of the XTALO/MCLK trace. The XTALO capacitor must be 10 pF, while the XTAL3I capacitor remains the typical 22 pF. If the CS9236 cannot be placed close to the CS4333, the buffered crystal circuit shown in Figure 3 or a MicroClock MK1444-02 clock generator may be used. Do not use separate 16.9344 MHz crystals/clock sources for the synthesizer and DAC.

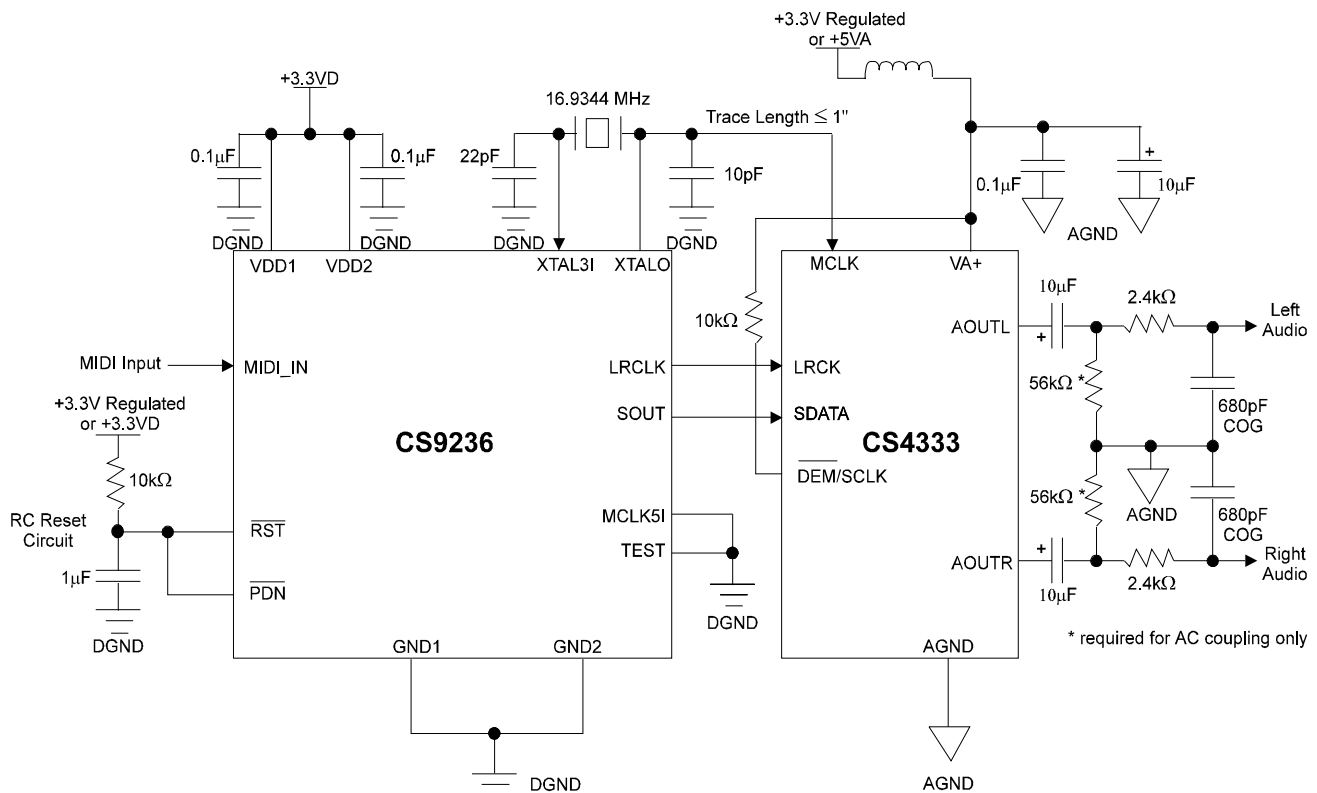

Figure 2. CS9236/CS4333 Typical Connections.

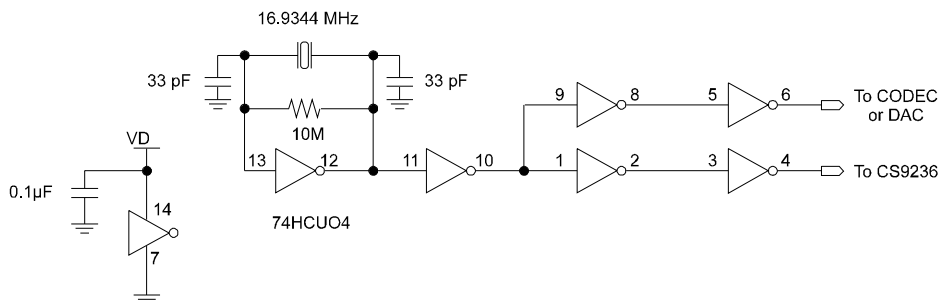

Figure 3. Buffered Crystal Oscillator Circuit.



## CS9236 Clocks and Timing Generation

The CS9236 internal timing is derived from one of two possible sources; the part may be supplied a 16.9344 MHz Master Clock signal from an external source, or the timing may be generated using the on-chip oscillator circuit in conjunction with an external 16.9344 MHz quartz crystal. When a Master Clock signal is provided to the CS9236 from an external device, the Master Clock signal should be connected to the CS9236 MCLK5I input pin and the XTAL3I input pin is grounded. When the CS9236 internal timing is generated using the on-chip oscillator circuit, a 16.9344 MHz quartz crystal is connected between the CS9236 XTAL3I input pin and the XTALO output pin, and the MCLK5I input pin is grounded. In this case, the XTALO output may also be used as a 384X master clock for the CS9236 digital audio output signal, SOUT.

## Power-Down Modes

The CS9236 provides a fully-static power-down mode of operation. The power-down mode is initiated either by assertion of the active-low  $\overline{\text{PDN}}$  signal, or by gating off of the MCLK5I input signal (via the CODEC DMCLK bit in CS4236B/7B/8B applications). In the power-down mode of operation, clock signals to virtually all of the CS9236 internal circuitry are gated off to minimize power consumption. The CS9236 device is fully static, so all internal states and register values will be retained during power-down, provided that power remains applied to the device and that the  $\overline{\text{RST}}$  signal remains inactive. Power-down operation is terminated either by deassertion of  $\overline{\text{PDN}}$  or by gating back on the MCLK5I input signal. The device will then resume normal operation.

## Digital Audio Interface

The CS9236 provides a stereo 16-bit serial digital audio output at a 44.1 ksample/s sampling rate. The CS9236 digital audio output is compatible with the Crystal Semiconductor CS4236B/37B/38B and CS4333 devices. The digital audio interface consists of the digital audio output signal, SOUT, and the associated left/right word clock output, LRCLK. Transitions of the SOUT and LRCLK signals are synchronous to the CS9236 crystal oscillator output clock, XTALO. The relationship between the CS9236 SOUT data output and the LRCLK clock output is indicated in Figure 4.

## Reset

The CS9236 is initialized/reset to a known default state using the  $\overline{\text{RST}}$  signal. The  $\overline{\text{RST}}$  signal should be applied at power-on time to initialize the part. Minimum  $\overline{\text{RST}}$  pulse width is 500 ns.

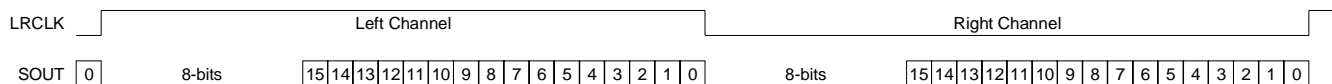

**Figure 4. Digital Audio Port Format.**

## **GENERAL MIDI (GM) MELODIC INSTRUMENTS AND PERCUSSION SOUNDS**

The CS9236 supports 128 melodic instruments and 47 percussive sounds as specified by the General MIDI Level 1 specification.

MIDI messages generally consist of a single status byte followed by one or two data bytes (Real-Time messages and System Exclusive messages are exceptions). The status byte is an eight-bit value which indicates the type of message, and for Channel Voice or Channel Mode messages, the MIDI channel number to which the message applies. The most significant bit of the Status byte is always a “1”. The most significant bit a MIDI Data byte is always a “0”, so a data byte contains only 7 bits of useful data. Status bytes and Data bytes for functions not implemented are ignored.

In General MIDI (GM) instruments like the CS9236, MIDI channels 1 - 9 and 11 - 16 are used for melodic instruments. On MIDI channels 1 - 9 and 11 - 16, the MIDI Program Change message is used to select the instrument to be used on a specific MIDI channel. The General MIDI melodic instrument set is listed in Table 1.

The General MIDI system reserves channel 10 for key-mapped percussion sounds. The General MIDI percussion map defines the association of percussion sounds to key numbers (note numbers) for use on channel 10. Program Change messages on channel 10 are ignored. The CS9236 includes default settings for the PAN, the REVERB SEND level, and the CHORUS SEND level for each of the General MIDI percussion sounds. The PAN setting used for a percussion sound on channel 10 is a function of both the CS9236 default value and the MIDI PAN value for channel 10 (PAN messages on channel 10 are interpreted by the CS9236 as relative, rather than absolute, values). For example, the default pan value for the Hand Clap is 54 (10 units left of center) and the default pan value for the Tambourine is 74 (10 units right of center). A MIDI PAN message on channel 10 indicating a new pan value of 50 (14 units left of center) for the channel would place the Hand Clap at 40 (24 units left of center), and the Tambourine at 60 (4 units left of center). A MIDI PAN message on channel 10 indicating a new pan value of 0 (64 units left of center, or “hard left”) for the channel would place the Hand Clap at 0 (hard left), and the Tambourine at 10 (54 units left of center). The REVERB SEND level used for a percussion sound on channel 10 will be either the default value for that percussion sound, or the MIDI REVERB SEND value

(MIDI Controller 91), whichever is greater. The CHORUS SEND level used for a percussion sound on channel 10 will be either the default value for that percussion sound, or the MIDI CHORUS SEND value (MIDI Controller 93), whichever is greater.

Some of the percussion instrument sounds available on channel 10 belong to “mutually exclusive groups”. Although multiple sounds may be generated simultaneously on channel 10 when operating in the normal POLY ON mode, no more than one sound from each of the mutually exclusive groups may sound at a given time. For example, the Open Hi-Hat (Note # 46), the Closed Hi-Hat (Note # 42), and the Pedal Hi-Hat (Note # 44) all belong to the same mutually exclusive group. If the Open Hi-Hat was already sounding when a MIDI NOTE ON message was received for the Closed Hi-Hat, the Closed Hi-Hat would be played while the Open Hi-Hat would be immediately forced into its release phase (the two notes would overlap only for the duration of the release phase of the Open Hi-Hat sound). A Crash Cymbal sound (not a member of this mutually exclusive group) which was also playing when the NOTE ON message was received would not be affected.

The General MIDI percussion sound map is given in Table 2. This table also indicates the mutually exclusive group membership for each of the percussion sounds as implemented in the CS9236.

PC#	Instrument name	PC#	Instrument name	PC#	Instrument name	PC#	Instrument name
1	Acoustic Grand Piano	33	Acoustic Bass	65	Soprano Sax	97	FX 1 (rain)
2	Bright Acoustic Piano	34	Electric Bass (finger)	66	Alto Sax	98	FX 2 (soundtrack)
3	Electric Grand Piano	35	Electric Bass (pick)	67	Tenor Sax	99	FX 3 (crystal)
4	Honky-tonk Piano	36	Fretless Bass	68	Baritone Sax	100	FX 4 (atmosphere)
5	Electric Piano 1	37	Slap Bass 1	69	Oboe	101	FX 5 (brightness)
6	Electric Piano 2	38	Slap Bass 2	70	English Horn	102	FX 6 (goblins)
7	Harpichord	39	Synth Bass 1	71	Bassoon	103	FX 7 (echoes)
8	Clavi	40	Synth Bass 2	72	Clarinet	104	FX 8 (sci-fi)
9	Celesta	41	Violin	73	Piccolo	105	Sitar
10	Glockenspiel	42	Viola	74	Flute	106	Banjo
11	Music Box	43	Cello	75	Recorder	107	Shamisen
12	Vibraphone	44	Contrabass	76	Pan Flute	108	Koto
13	Marimba	45	Tremelo Strings	77	Blown Bottle	109	Kalimba
14	Xylophone	46	Pizzicato Strings	78	Shakuhachi	110	Bag Pipe
15	Tubular Bells	47	Orchestral Harp	79	Whistle	111	Fiddle
16	Dulcimer	48	Timpani	80	Ocarina	112	Shanai
17	Drawbar Organ	49	String Ensemble 1	81	Lead 1 (square)	113	Tinkle Bell
18	Percusive Organ	50	String Ensemble 2	82	Lead 2 (sawtooth)	114	Agogo
19	Rock Organ	51	SynthStrings 1	83	Lead 3 (calliope)	115	Steel Drums
20	Church Organ	52	SynthStrings 2	84	Lead 4 (chiff)	116	Woodblock
21	Reed Organ	53	Choir Aahs	85	Lead 5 (charang)	117	Taiko Drum
22	Accordion	54	Voice Oohs	86	Lead 6 (voice)	118	Melodic Tom
23	Harmonica	55	Synth Voice	87	Lead 7 (fifths)	119	Synth Drum
24	Tango Accordion	56	Orchestra Hit	88	Lead 8 (bass + lead)	120	Reverse Cymbal
25	Acoustic Guit. (nylon)	57	Trumpet	89	Pad 1 (new age)	121	Guitar Fret Noise
26	Acoustic Guit. (steel)	58	Trombone	90	Pad 2 (warm)	122	Breath Noise
27	Electric Guitar (jazz)	59	Tuba	91	Pad 3 (polysynth)	123	Seashore
28	Electric Guitar (clean)	60	Muted Trumpet	92	Pad 4 (choir)	124	Bird Tweet
29	Electric Guitar (muted)	61	French Horn	93	Pad 5 (bowed)	125	Telephone Ring
30	Overdriven Guitar	62	Brass Section	94	Pad 6 (metallic)	126	Helicopter
31	Distortion Guitar	63	SynthBrass 1	95	Pad 7 (halo)	127	Applause
32	Guitar harmonics	64	SynthBrass 2	96	Pad 8 (sweep)	128	Gunshot

**Table 1. General MIDI Melodic Instrument Map (MIDI channels 1 - 9, 11 - 16)**

<b>Note #</b>	<b>Drum Sound</b>	<b>Excl #</b>	<b>Note #</b>	<b>Drum Sound</b>	<b>Excl #</b>
35	Acoustic Bass Drum		59	Ride Cymbal 2	
36	Bass Drum 1		60	Hi Bongo	
37	Side Stick		61	Low Bongo	
38	Acoustic Snare		62	Mute Hi Conga	
39	Hand Clap		63	Open Hi Conga	
40	Electric Snare		64	Low Conga	
41	Low Floor Tom		65	High Timbale	
42	Closed Hi-Hat 1	1	66	Low Timbale	
43	High Floor Tom		67	High Agogo	
44	Pedal Hi-Hat 1	1	68	Low Agogo	
45	Low Tom		69	Cabasa	
46	Open Hi-Hat 1	1	70	Maracas	
47	Low Mid Tom		71	Short Whistle	2
48	Hi Mid Tom		72	Long Whistle	2
49	Crash Cymbal 1		73	Short Guiro	3
50	High Tom		74	Long Guiro	3
51	Ride Cymbal 1		75	Claves	
52	Chinese Cymbal		76	Hi Wood Block	
53	Ride Bell		77	Low Wood Block	
54	Tambourine		78	Mute Cuica	4
55	Splash Cymbal		79	Open Cuica	4
56	Cowbell		80	Mute Triangle	5
57	Crash Cymbal 2		81	Open Triangle	5
58	Vibraslap				

**Table 2. General MIDI Percussion Map (MIDI channel 10 only)**

## MIDI IMPLEMENTATION

The CS9236 MIDI interpreter responds to all MIDI messages specified for General MIDI Level 1.0 compliance. The GM messages include NOTE ON, NOTE OFF, PROGRAM CHANGE, CHANNEL PRESSURE, PITCH BEND CHANGE, MODULATION WHEEL (Controller 1), DATA ENTRY (Controllers 6 & 18), VOLUME (Controller 7), PAN (Controller 10), EXPRESSION (Controller 11), DAMPER PEDAL/SUSTAIN (Controller 64), PITCH BEND SENSITIVITY (RPN 00), FINE TUNING (RPN 01), COARSE TUNING (RPN 02), RESET ALL CONTROLLERS, and ALL NOTES OFF.

In addition, the CS9236 MIDI interpreter responds to SOSTENUTO (Controller 66), EFFECT 1/REVERB SEND LEVEL (Controller 91), EFFECT 3/CHORUS SEND LEVEL (Controller 93), ALL SOUNDS OFF, OMNI MODE OFF (treated as ALL NOTES OFF), OMNI MODE ON (treated as ALL NOTES OFF), MONO MODE ON, POLY MODE ON, ACTIVE SENSING, SYSTEM RESET, and System Exclusive messages (System Exclusive messages may be used to enable/disable channel pressure and to enable/disable internal test mode).

The MIDI interpreter correctly interprets MIDI data streams transmitted using Running Status. “Running Status” is applicable to Channel Voice messages and to Channel Mode Messages as follows: when a group of sequential messages in a MIDI data stream should have the same status byte value, the status byte must be included for the first message in the group, but may be omitted for the subsequent messages of the same status byte value. Running status allows long strings of Channel Voice or Channel Mode messages to be sent using only data bytes, with the status byte inferred by the last Channel Voice or Channel Mode status byte received. A message with a different status byte value will reset the running status. Note that even messages which are “ignored” or not otherwise processed by the CS9236 will reset the running status mode. Real-Time messages are an exception to this rule: Real-Time messages do not affect running status.

A MIDI Implementation Chart for the CS9236 is given in Table 3.

### *Channel Voice Messages*

Channel Voice messages are used to control instrument voices. Channel Voice messages consist of a status byte followed by one or two data bytes. Channel Voice messages which are

processed by the CS9236 include the NOTE ON, NOTE OFF, CONTROL CHANGE, PROGRAM CHANGE, PITCH BEND CHANGE, and CHANNEL PRESSURE messages.

### *Control Change Messages*

The CS9236 processes MIDI Controller numbers 1 (MODULATION WHEEL), 6 (DATA ENTRY MSB), 7 (CHANNEL VOLUME), 10 (PAN), 11 (EXPRESSION), 38 (DATA ENTRY LSB), 64 (DAMPER PEDAL), 66 (SOSTENUTO), 91 (REVERB DEPTH), 93 (CHORUS DEPTH), 100 (Register Parameter LSB), 101 (Register Parameter MSB), 120 (ALL SOUNDS OFF), and 121 (RESET ALL CONTROLLERS).

### *Registered Parameters*

MIDI “Registered Parameter” data is transmitted to the CS9236 using controller numbers 100 (Registered Parameter LSB), 101 (Registered Parameter MSB), 6 (Data Entry MSB), and 38 (Data Entry LSB). To transfer parameter data to the CS9236, the parameter number for the parameter to be updated is first selected using MIDI Controllers 100 and 101, and then the data value for the selected parameter is transmitted using controller numbers 6 and 38. The CS9236 responds to the MIDI Registered Parameters for PITCH BEND SENSITIVITY (RPN00), FINE TUNING (RPN01), and COARSE TUNING (RPN02).

### *Channel Mode Messages*

The CS9236, like other popular synthesizer products, operates in a mode sometimes referred to as “Multimode”, described as follows:

The CS9236 MIDI controller consists of 16 receiver channels (one receiver channel for each of the 16 MIDI channels). Each receiver channel receives MIDI messages on its dedicated MIDI channel. Each receiver channel can also receive MODE messages on its dedicated MIDI channel (the MIDI channel for each receiver is also the “basic channel” for that receiver) as follows: Each receiver channel is considered to operate only in OMNI OFF mode, (each receiver channel can only receive data on one MIDI channel). When a receiver channel receives an OMNI ON message, it stops all ongoing notes but remains in OMNI OFF mode.

Each receiver channel can accept a POLY ON message or a MONO ON message. The POLY ON message sets the receiv-

er channel to “Mode 3” operation (OMNI OFF/POLY). This is the default mode of operation for all receiver channels. In mode 3, the receiver channel responds to MIDI messages on it's dedicated MIDI channel polyphonically (it can play multiple MIDI notes simultaneously).

The MONO ON message sets the receiver channel to “Mode 4” operation (OMNI OFF/MONO). In mode 4, the receiver channel responds to MIDI messages on it's dedicated MIDI channel monophonically (it can only play one MIDI note at a time). In this mode, if a NOTE ON message is received on the receiver's MIDI channel while a note is already sounding, the receiver will quickly turn off the note which is already sounding and play the new note.

### ***System Realtime Messages***

MIDI SYSTEM REAL TIME messages may occur at any point in the MIDI data stream, including between the Status and Data bytes of another MIDI message. SYSTEM REAL TIME messages are not interpreted as a new receiver status and do not affect the operation of Running Status. The MIDI SYSTEM REAL TIME messages are: TIMING CLOCK (F8H), START (FAH), CONTINUE (FBH), STOP (FCH), ACTIVE SENSING (FEH), and SYSTEM RESET (FFH). The CS9236 processes the ACTIVE SENSING and SYSTEM RESET messages only. The TIMING CLOCK, START, CONTINUE and STOP messages are ignored.

### ***System Exclusive Messages***

The CS9236 supports MIDI System Exclusive Messages for enabling/disabling receipt of MIDI Channel Pressure and for enabling/disabling of the CS9236 test tone. The System Exclusive Manufacturer ID assigned for Crystal Semiconductor Corporation is 0x00, 0x01, 0x02. The Product ID for the CS9236 is 0x01, and the Version Number is 0x01.

The CS9236 will power-up with Channel Pressure disabled. To enable Channel Pressure, the ENABLE RECOGNITION OF MIDI CHANNEL PRESSURE System Exclusive message must be sent. Channel Pressure is disabled by sending the DISABLE RECOGNITION OF MIDI CHANNEL PRESSURE message. Likewise, for testing purposes, a feature to enable a test tone is available. To begin playing the test tone, the ENABLE TEST TONE System Exclusive message must be sent. To turn the tone off, the DISABLE TEST TONE message must be sent.

WAVETABLE SYNTHESIZER  
Model: CS9236

## MIDI Implementation Chart

Date: July 11, 1996  
Version: 1.00

Function		Transmitted	Recognized	Remarks
<b>Basic Channel</b>	Default	X	1 - 16	"Multi-mode operation", Note 1.
	Changed	X	X	
<b>Mode</b>	Default	X	Mode 3	Channels 1 - 16, Note 1. Note 1 Note 1
	Messages	X	OMNI OFF, POLY, MONO (m=1)	
	Altered	*****	OMNI ON > OMNI OFF	
<b>Note Number</b>	True Voice	X	0 - 127	
		*****	0 - 127	
<b>Velocity</b>	Note On	X	O	
	Note Off	X	X	
<b>After Touch</b>	Key's	X	X	
	Channel	X	O	
<b>Pitch Bend</b>		X	O	
<b>Control Change</b>	1	X	O	Modulation Wheel Data Entry MSB, LSB Channel Volume Pan Expression Damper Pedal (Sustain) Sostenuto Effect 1 Depth (Reverb) Effect 3 Depth (Chorus) RPN LSB, MSB
	6, 38	X	O	
	7	X	O	
	10	X	O	
	11	X	O	
	64	X	O	
	66	X	O	
	91	X	O	
	93	X	O	
	100, 101	X	O	
<b>Program Change</b>	True Number	X	O	Program Numbers 1 - 128
		*****	0 - 127	
<b>System Exclusive</b>		X	O	
<b>System Common</b>	Song Position	X	X	
	Song Select	X	X	
	Tune Request	X	X	
<b>System Real Time</b>	Clock	X	X	
	Commands	X	X	
<b>Aux Messages</b>	All Sounds Off	X	O	
	Reset All Controllers	X	O	
	Local On/Off	X	X	
	All Notes Off	X	O	
	Active Sensing	X	O	
	System Reset	X	O	
	Poly On	X	O	
	Mono On	X	O	
Notes 1. For Mode selection, this device responds as 16 MIDI receivers, one for each MIDI channel. Each MIDI receiver accepts mode messages on it's own MIDI channel (basic channel = MIDI channel of receiver). Each MIDI receiver operates in MODE 3 (default) or MODE 4 only.				

MODE 1: Omni On, Poly  
MODE 3: Omni Off, Poly

MODE 2: Omni On, Mono  
MODE 4: Omni Off, Mono

0: Yes  
X: No

**Table 3. MIDI Implementation Chart**

**Message Definitions***Channel Voice Messages***NOTE ON**

9nH	kkH	vvH
n = MIDI channel number		0 - FH (1 - 16)
kk = note number		00 - 7FH (0 - 127)
vv = velocity		00 - 7FH (1 - 127)

The NOTE ON message is used to turn on a note for a specified MIDI channel. Note number 3CH (60) is Middle C. In the CS9236, the NOTE ON velocity value may control several characteristics of the resulting sound. The velocity value is used to scale the amplitude envelope for all of the instruments in the CS9236 according to the following formula:

$$\text{Max\_env} = (\text{constant}) * 10^{((127 - \text{velocity\_value}) * (-0.00835))}.$$

For certain instruments, the velocity value also affects characteristics such as low-pass filter cutoff frequency, allowing the timbre of the instrument to change subtly as a function of velocity. MIDI controllers/transmitters which are not velocity sensitive should use velocity = 40H (64). A NOTE ON message with velocity = 00 is defined to be a NOTE OFF message with NOTE OFF velocity of 40H (this allows long strings of NOTE ON and NOTE OFF events to be sent as data bytes only using running status).

**NOTE OFF**

8nH	kkH	vvH
	or	
9nH	kkH	00H
n = MIDI channel number		0 - FH (1 - 16)
kk = note number		00 - 7FH (0 - 127)
vv = velocity		00 - 7FH (ignored)

The NOTE OFF message is used to turn off a note on a specified MIDI channel (this message triggers the “release” portion of the note’s amplitude envelope, wherein the amplitude decays to zero). Note number 3CH (60) = Middle C. MIDI controllers/transmitters which are not velocity sensitive should use velocity = 40H. The NOTE OFF velocity value is ignored by the CS9236. A note can be turned off using the NOTE OFF message (status byte = 8nH) or using the NOTE ON message (9nH) with velocity = 00. The NOTE ON message with velocity = 00 is defined to be a NOTE OFF message with NOTE OFF velocity of 40H (this allows long strings of NOTE ON and NOTE OFF events to be sent as data bytes only using running status). The DAMPER PEDAL (Sustain) ON (MIDI Controller 64) takes priority over the NOTE OFF and ALL NOTES OFF messages: the NOTE OFF or ALL NOTES OFF messages are recognized, but not acted on until the DAMPER PEDAL is released (OFF). The SOSTENUTO PEDAL (MIDI Controller 66) ON takes priority over the NOTE OFF and ALL NOTES OFF messages in a similar way, with the exception that SOSTENUTO only affects notes which were already active at the time that SOSTENUTO was switched from OFF to ON (See description of DAMPER PEDAL and SOSTENUTO messages).



*Channel Voice Messages (Continued)***PROGRAM CHANGE**

CnH	ppH	
n = MIDI channel number		0 - FH (1 - 16)
pp = program number		00 - 7FH (1 - 128)

For the “melodic instrument channels” (MIDI channels 1 - 9, 11 - 16), the PROGRAM CHANGE message is used to select the melodic instrument to be used on a specified MIDI channel. MIDI channel 10 is used for the General MIDI percussion set, and PROGRAM CHANGE messages on MIDI channel 10 are ignored.

In this document, the melodic instruments are numbered from 1 through 127 (MIDI program number value +1). The Program Change message does not affect notes in progress. Notes in Progress continue to sound using their original instrument selection. Note On messages received after the Program Change message will sound using the new instrument selection.

**CHANNEL PRESSURE (Channel Aftertouch)**

DnH	vvH	
n = MIDI channel number		0 - FH (1 - 16)
vv = value		00 - 7FH (0 - 127) <OFF>

In the CS9236, the MIDI Channel Pressure message may be used to control the pitch modulation (vibrato) level on a specified channel. Recognition of CHANNEL PRESSURE may be enabled or disabled in the CS9236 using MIDI System Exclusive messages. Recognition of CHANNEL PRESSURE is disabled by default (CHANNEL PRESSURE messages are ignored). When recognition of CHANNEL PRESSURE is enabled, the CHANNEL PRESSURE value is summed with the current MODULATION WHEEL value and with the default modulation level defined for the selected instrument on the specified channel to determine the actual vibrato level applied to the sound. When enabled, CHANNEL PRESSURE at maximum value will contribute a modulation (vibrato) depth of 50 cents. The response curve is linear. The total depth, resulting from CHANNEL PRESSURE, MODULATION WHEEL, and default modulation level, may be as high as one semitone. When enabled, CHANNEL PRESSURE affects all notes playing on the specified channel. Pitch modulation in the CS9236 is implemented using independent low frequency oscillator (LFO) implementations for each note.

Some of the instruments implemented in the CS9236 include a default pitch envelope (the pitch of a note begins slightly sharp or flat, and then ramps to the final pitch for the note). For notes with default pitch envelopes, pitch modulation (vibrato) will begin only after the pitch envelope has reached final pitch.

*Channel Voice Messages (Continued)***PITCH BEND CHANGE**

EnH	llH	mmH
n = MIDI channel number		0 - FH (1 - 16)
mm,ll = value		00,00 - 40,00 - 7FH,7FH (-8192 - 0 - 8192)

The PITCH BEND CHANGE message is used to control a pitch offset from the values specified in the NOTE ON messages received on the specified channel. The PITCH BEND CHANGE message applies to all notes on the specified channel. The default value for PITCH BEND CHANGE is zero. The pitch bend range is set by the PITCH BEND SENSITIVITY message (MIDI Controller 00). The default pitch bend range is +/- 2 semitones (a PITCH BEND CHANGE value of 8192 would result in a pitch change of +2 semitones). The maximum pitch bend range is +/- 24 semitones (see PITCH BEND SENSITIVITY message description).

*Control Change Messages***MODULATION WHEEL (CONTROLLER 1)**

BnH	01H	vvH
n = MIDI channel number		0 - FH (1 - 16)
vv = modulation depth		00 - 7FH (0 - 127)

In the CS9236, the MODULATION WHEEL message (MIDI Controller 1) is used to control the pitch modulation (vibrato) level on a specified channel. The MODULATION WHEEL depth value is summed with the current CHANNEL PRESSURE value and with the default modulation level defined for the selected instrument on the specified channel to determine the actual vibrato level applied to the sound. The MODULATION WHEEL at maximum depth value will contribute a modulation (vibrato) depth of 50 cents. The response curve is linear. The total depth, resulting from CHANNEL PRESSURE, MODULATION WHEEL, and default modulation level, may be as high as one semitone. The MODULATION WHEEL affects all notes playing on the specified channel. Pitch modulation in the CS9236 is implemented using independent low frequency oscillator (LFO) implementations for each note.

Some of the instruments implemented in the CS9236 include a default pitch envelope (the pitch of a note begins slightly sharp or flat, and then ramps to the final pitch for the note). For notes with default pitch envelopes, pitch modulation (vibrato) will begin only after the pitch envelope has reached final pitch.

**DATA ENTRY (CONTROLLERS 6 and 38)**

BnH	06H	mmH
BnH	26H	llH
n = MIDI channel number		0 - FH (1 - 16)
mm = data value MSB for specified RPN (see REGISTERED PARAMETER NUMBER description)		
ll = data value LSB for specified RPN (see REGISTERED PARAMETER NUMBER description)		

MIDI "Registered Parameter" data is transmitted to the CS9236 using controller numbers 100 (Registered Parameter LSB), 101 (Registered Parameter MSB), 6 (Data Entry MSB), and 38 (Data Entry LSB). To transfer parameter data to the CS9236, the parameter number for the parameter to be updated is first selected using MIDI Controllers 100 and 101, and then the data value for the selected parameter is transmitted using controller numbers 6 and 38. See description of REGISTERED PARAMETER NUMBER (Controllers 100 and 101).

**VOLUME (CONTROLLER 7)**

BnH	07H	vvH
n = MIDI channel number		0 - FH (1 - 16)
vv = volume		00 - 7FH (0 - 127)

The VOLUME message (MIDI Controller 7) is used in conjunction with the MIDI EXPRESSION message (Controller 11) to control the overall volume of notes on a specified MIDI channel. The VOLUME and EXPRESSION curves are described by the following equation:

$$\text{Attenuation from full scale (dB)} = 40 \ln ((\text{VOLUME\_value} * \text{EXPRESSION\_value}) / (127^2))$$

The CS9236 default value for VOLUME is 100.

*Control Change Messages (Continued)*

<b>PAN (CONTROLLER 10)</b>		
BnH	0AH	vvH
n = MIDI channel number		0 - FH (1 - 16)
vv = pan		00 - 40 - 7FH (0 - 64 - 127) <Left - Center - Right>
<p>The PAN message (MIDI Controller 10) is used to control the left/right output placement for notes played on the specified MIDI channel. A PAN value of 0 indicates hard left, 64 indicates center (equally balanced between left and right), and 127 indicates hard right. The CS9236 implements an “equal-power” pan scaling as indicated by the following formulae:</p> <p>Left_scaling = ((127 - PAN_value) / 127) ^ 0.5  Right_scaling = (PAN_value / 127) ^ 0.5</p> <p>On the melodic instrument channels (MIDI channels 1 - 9, 11 - 16), the MIDI PAN value is absolute (the received value replaces the default value for the instrument selected on the specified channel). On the percussion channel (MIDI channel 10) the MIDI PAN value is relative to the default value for each of the individual percussion sounds.</p>		
<b>EXPRESSION (CONTROLLER 11)</b>		
BnH	0BH	vvH
n = MIDI channel number		0 - FH (1 - 16)
vv = expression		00 - 7FH (0 - 127)
<p>The VOLUME message (MIDI Controller 7) is used in conjunction with the MIDI EXPRESSION message (Controller 11) to control the overall volume of notes on a specified MIDI channel. The VOLUME and EXPRESSION curves are described by the following equation:</p> <p>Attenuation from full scale (dB) = 40 ln ((VOLUME_value * EXPRESSION_value) / (127^2))</p> <p>The CS9236 default value for EXPRESSION is 127.</p>		
<b>DAMPER PEDAL/SUSTAIN (CONTROLLER 64)</b>		
BnH	40H	vvH
n = MIDI channel number		0 - FH (1 - 16)
vv = control value		00 - 3FH (0 - 63) <OFF> 40 - 7FH (64 - 127) <ON>
<p>The DAMPER PEDAL (Controller 64) allows notes on a specified MIDI channel to continue sounding after their corresponding NOTE OFF messages have been received. The DAMPER PEDAL ON state takes priority over the NOTE OFF and ALL NOTES OFF messages: the NOTE OFF or ALL NOTES OFF messages are recognized, but not acted on until the DAMPER PEDAL is set OFF (released). The DAMPER PEDAL ON state results in progression of the normal sustain envelope of ongoing notes.</p>		

*Control Change Messages (Continued)****SOSTENUTO (CONTROLLER 66)***

<b>BnH</b>	<b>40H</b>	<b>vvH</b>
n = MIDI channel number		0 - FH (1 - 16)
vv = control value		00 - 3FH (0 - 63) <OFF> 40 - 7FH (64 - 127) <ON>

The effect of SOSTENUTO is similar to DAMPER PEDAL (SUSTAIN), except that SOSTENUTO only affects notes which were already active at the time that SOSTENUTO was switched ON. Notes which were already playing when the SOSTENUTO ON message is received will be sustained until the corresponding NOTE OFF message is received or until SOSTENUTO is turned OFF, whichever occurs later. NOTE ON messages which are received after SOSTENUTO has been switched ON are not affected. The CS9236 default value for SOSTENUTO is zero (Off).

***EFFECT 1 DEPTH/REVERB SEND LEVEL (CONTROLLER 91)***

<b>BnH</b>	<b>5BH</b>	<b>vvH</b>
n = MIDI channel number		0 - FH (1 - 16)
vv = reverb send depth		00 - 7FH (0 - 127)

The REVERB SEND LEVEL message (MIDI Controller 91) is used to adjust the amount of reverb effect applied to sounds played on the specified MIDI channel. Each melodic instrument (MIDI channels 1 - 9, 11 - 16) and each individual percussion sound (MIDI channel 10) implemented in the CS9236 has a predefined default reverb send level. The reverb send level used when a sound is produced is either the value received from a REVERB SEND LEVEL message (MIDI Controller 91) or the default for the melodic instrument (or percussion sound) currently selected on the specified MIDI channel, whichever is greater. The CS9236 reverb send level response curve is exponential.

***EFFECT 3 DEPTH/CHORUS SEND LEVEL (CONTROLLER 93)***

<b>BnH</b>	<b>5DH</b>	<b>vvH</b>
n = MIDI channel number		0 - FH (1 - 16)
vv = chorus send depth		00 - 7FH (0 - 127)

The CHORUS SEND LEVEL message (MIDI Controller 93) is used to adjust the amount of chorus effect applied to sounds played on the specified MIDI channel. Each melodic instrument (MIDI channels 1 - 9, 11 - 16) and each individual percussion sound (MIDI channel 10) implemented in the CS9236 has a predefined default chorus send level. The chorus send level used when a sound is produced is either the value received from a CHORUS SEND LEVEL message (MIDI Controller 93) or the default for the melodic instrument (or percussion sound) currently selected on the specified MIDI channel, whichever is greater. The CS9236 chorus send level response curve is exponential.

*Control Change Messages (Continued)***REGISTERED PARAMETER NUMBER (RPN) (CONTROLLERS 100 and 101)**

BnH	65H	mmH
BnH	64H	llH

n = MIDI channel number            0 - FH (1 - 16)  
mm = RPN parameter number (MSB)  
ll = RPN parameter number (LSB)

MIDI "Registered Parameter" data is transmitted to the CS9236 using controller numbers 100 (Registered Parameter LSB), 101 (Registered Parameter MSB), 6 (Data Entry MSB), and 38 (Data Entry LSB). To transfer parameter data to the CS9236, the parameter number for the parameter to be updated is first selected using MIDI Controllers 100 and 101, and then the data value for the selected parameter is transmitted using controller numbers 6 and 38. The CS9236 recognizes MIDI Registered Parameter Numbers 00 (PITCH BEND SENSITIVITY), 01 (FINE TUNING), and 02 (COURSE TUNING) as described in the following paragraphs.

## Registered Parameters

### **PITCH BEND SENSITIVITY (RPN 00)**

RPN		DATA	
MSB	LSB	MSB	LSB
00H	00H	mmH	llH

#### **DESCRIPTION**

#### **PITCH BEND SENSITIVITY (RPN 00)**

- mm: sensitivity in semitones
- Range is 00 - 18H (+/-0 to +/-24 semitones, default is +/-2 semitones)
- ll: sensitivity in cents
- Ignored

The PITCH BEND SENSITIVITY parameter (MIDI Registered Parameter Number 00) is used to set the amount of pitch change which will result from subsequently received PITCH BEND CHANGE messages. The PITCH BEND SENSITIVITY is channel specific (independent values are maintained for each MIDI channel). The CS9236 default sensitivity is +/-2 semitones (a maximum value of PITCH BEND CHANGE will result in a pitch change of +2 semitones, the minimum value of PITCH BEND CHANGE will result in a pitch change of -2 semitones). The maximum sensitivity for the CS9236 is +/-24 semitones (+/- two octaves). See description of REGISTERED PARAMETER NUMBER (Controllers 100 and 101) and DATA ENTRY (Controllers 6 and 38) Control Change messages.

### **FINE TUNING (RPN 01)**

RPN		DATA	
MSB	LSB	MSB	LSB
00H	01H	mmH	llH

#### **DESCRIPTION**

#### **FINE TUNING (RPN 01)**

- mm,ll: fine pitch offset in cents from A440
- resolution is 100/8192 cents
- range is 00,00 - 40,00 - 7FH,7FH
- (-8192\*100/8192 - 0 - +8191\*100/8192 cent)

The FINE TUNING parameter (MIDI Registered Parameter Number 01) is used for fine tuning of the pitch of instruments played on the specified MIDI channel. The FINE TUNING parameter provides high resolution control of tuning for pitch changes of up to one semitone. The COARSE TUNING parameter (MIDI Registered Parameter Number 02) provides coarse tuning in semitone units. See description of REGISTERED PARAMETER NUMBER (Controllers 100 and 101) and DATA ENTRY (Controllers 6 and 38) Control Change messages.

*Registered Parameters (Continued)*

<b>COARSE TUNING (RPN 02)</b>			
RPN	DATA		
MSB	LSB	MSB	LSB
00H	02H	mmH	llH
<b>DESCRIPTION</b>			
<b>COARSE TUNING (RPN 02)</b>			
mm: pitch offset in semitones from A440			
resolution is 100 cents (one semitone)			
range is 28H - 40 - 58H (-24 - 0 - +24 semitone)			
ll: ignored per MIDI spec			
The COARSE TUNING parameter (MIDI Registered Parameter Number 02) is used for fine tuning of the pitch of instruments played on the specified MIDI channel. The COARSE TUNING parameter provides coarse tuning in semitone units. The FINE TUNING parameter (MIDI Registered Parameter Number 01) provides high resolution control of tuning for pitch changes of up to one semitone. See description of REGISTERED PARAMETER NUMBER (Controllers 100 and 101) and DATA ENTRY (Controllers 6 and 38) Control Change messages.			



*Channel Mode Messages****ALL SOUNDS OFF (Controller 120)***

BnH            78H            00H  
 n = MIDI channel number            0 - FH (1 - 16)

The ALL SOUNDS OFF message is used to immediately turn off all sounds on the specified MIDI channel. Sounds which are turned off using ALL SOUNDS OFF do not proceed through the normal release stage of their amplitude envelope(s).

***RESET ALL CONTROLLERS (Controller 121)***

BnH            79H            00H  
 n = MIDI channel number            0 - FH (1 - 16)

The RESET ALL CONTROLLERS message is used to reset MIDI Controller values for the specified MIDI channel back to their initial/default states. The RESET ALL CONTROLLERS message will restore the following parameter values in the CS9236 (Note that restoration of the PITCH BEND CHANGE value in response to RESET ALL CONTROLLERS will not affect notes already in progress):

<b>Controller/MIDI parameter</b>	<b>Value after RESET ALL CONTROLLERS</b>
PITCH BEND CHANGE	40H, 40H (center)
CHANNEL PRESSURE	0H (Off)
MODULATION WHEEL	0H (Off)
EXPRESSION	7FH (127)
HOLD1 (Sustain)	0H (Off)

***ALL NOTES OFF (Controller 123)***

BnH            7BH            00H  
 n = MIDI channel number            0 - FH (1 - 16)

The ALL NOTES OFF message is used to turn off all notes on the specified MIDI channel. Notes which are turned off using ALL NOTES OFF will proceed through the normal release stage of their amplitude envelope(s). The DAMPER PEDAL (MIDI Controller 64) ON takes priority over the NOTE OFF and ALL NOTES OFF messages: the NOTE OFF or ALL NOTES OFF messages are recognized, but not acted on until the DAMPER PEDAL is released (OFF). The SOSTENUTO PEDAL (MIDI Controller 66) ON takes priority over the NOTE OFF and ALL NOTES OFF messages in a similar way, with the exception that SOSTENUTO only affects notes which were already active at the time that SOSTENUTO was switched from OFF to ON (See description of DAMPER PEDAL and SOSTENUTO messages).

***OMNI MODE OFF (Controller 124)***

BnH            7CH            00H  
 n = MIDI channel number            0 - FH (1 - 16)

The CS9236 responds to the OMNI MODE OFF message as if it were an ALL NOTES OFF message (See ALL NOTES OFF). The specified channel remains in OMNI OFF mode (All channels operate only in OMNI OFF mode in the CS9236).

*Channel Mode Messages (Continued)***OMNI MODE ON (Controller 125)**

BnH	7DH	00H
n = MIDI channel number		0 - FH (1 - 16)

The CS9236 responds to the OMNI MODE ON message as if it were an ALL NOTES OFF message (See ALL NOTES OFF). The specified channel remains in OMNI OFF mode (All channels operate only in OMNI OFF mode in the CS9236).

**MONO MODE ON (Controller 126)**

BnH	7EH	mmH
n = MIDI channel number		0 - FH (1 - 16)
mm = number of mono		00 - 10H (0 - 16) <ignored>

On receipt of the MONO MODE ON message, the CS9236 performs ALL SOUNDS OFF on the specified MIDI channel (see description of ALL SOUNDS OFF message), and the specified channel is set to Mode 4 (OMNI OFF/MONO). In mode 4, the specified channel will respond to MIDI messages monophonically (it can only play one MIDI note at a time). In this mode, if a NOTE ON message is received on the specified MIDI channel while a note is already sounding, the new note will be played while the old/ongoing note is forced into the release phase of its amplitude envelope (the notes will overlap for the duration of the release phase of the older note).

**POLY MODE ON (Controller 127)**

BnH	7FH	00H
n = MIDI channel number		0 - FH (1 - 16)

On receipt of the POLY MODE ON message, the CS9236 performs ALL SOUNDS OFF on the specified MIDI channel (see description of ALL SOUNDS OFF message), and the specified channel is set to Mode 3 (OMNI OFF/POLY). In mode 3, the specified channel will respond to MIDI messages polyphonically (it can play multiple MIDI notes simultaneously). Mode 3 is the default mode of operation for each MIDI channel in the CS9236.

---

*System Real Time Messages****ACTIVE SENSING***

FEH

MIDI Transmitters which are using active sensing will send the ACTIVE SENSING message (FEH) every 300 ms maximum (270 recommended) whenever there is no other MIDI data being transmitted. The CS9236 defaults to Active Sensing OFF mode of operation. When the CS9236 detects an ACTIVE SENSING message, it begins operating in Active Sensing ON mode. In Active Sensing ON mode, the CS9236 monitors the elapsed time between receipt of MIDI messages. If the elapsed time exceeds 372 ms., then the CS9236 executes ALL SOUNDS OFF and RESET ALL CONTROLLERS on each MIDI channel and returns to Active Sensing OFF mode.

***SYSTEM RESET***

FFH

The SYSTEM RESET message will cause the CS9236 to set Mode 3 (OMNI OFF/POLY) operation for each MIDI channel, execute ALL SOUNDS OFF and RESET ALL CONTROLLERS on each MIDI channel, return to Active Sensing OFF mode, and return to initialized power-up status.

*System Exclusive Messages****ENABLE RECOGNITION OF MIDI CHANNEL PRESSURE***

F0H 00H 01H 02H 01H 01H 01H F7H

F0H = MIDI System Exclusive Header

00H, 01H, 02H =

System Exclusive Manufacturer ID:

Crystal Semiconductor Corp.

01H = Product ID: CS9236

01H = Model/Version ID: 01

01H = Message Type: Enable Channel Pressure

F7H = End of System Exclusive flag (EOX)

Receipt of the ENABLE RECOGNITION OF MIDI CHANNEL PRESSURE system exclusive message will cause the CS9236 to recognize subsequent MIDI CHANNEL PRESSURE messages on all MIDI channels. (See description of CHANNEL PRESSURE message). By default, the CS9236 disables recognition of CHANNEL PRESSURE.

***DISABLE RECOGNITION OF MIDI CHANNEL PRESSURE***

F0H 00H 01H 02H 01H 01H 02H F7H

F0H = MIDI System Exclusive Header

00H, 01H, 02H =

System Exclusive Manufacturer ID:

Crystal Semiconductor Corp.

01H = Product ID: CS9236

01H = Model/Version ID: 01

02H = Message Type: Disable Channel Pressure

F7H = End of System Exclusive flag (EOX)

Receipt of the DISABLE RECOGNITION OF MIDI CHANNEL PRESSURE system exclusive message will cause the CS9236 to ignore subsequent MIDI CHANNEL PRESSURE messages on all MIDI channels. (See description of CHANNEL PRESSURE message). By default, the CS9236 disables recognition of CHANNEL PRESSURE.

*System Exclusive Messages (Continued)****ENABLE TEST TONE***

F0H 00H 01H 02H 01H 01H 03H F7H

F0H = MIDI System Exclusive Header

00H, 01H, 02H =

System Exclusive Manufacturer ID:

Crystal Semiconductor Corp.

01H = Product ID: CS9236

01H = Model/Version ID: 01

03H = Message Type: Enable Test Mode

F7H = End of System Exclusive flag (EOX)

Receipt of the ENABLE TEST TONE system exclusive message will cause the CS9236 to output a 1 kHz sinusoidal test tone. The test tone output will be affected by MIDI Channel Voice Messages for MIDI channel 10 (i.e. VOLUME, EXPRESSION, PAN, PITCH BEND CHANGE, MODULATION, REVERB SEND LEVEL, CHORUS SEND LEVEL). The test tone output level under default conditions for VOLUME, EXPRESSION, PAN, PITCH BEND CHANGE, MODULATION, REVERB SEND LEVEL, and CHORUS SEND LEVEL on channel 10 is 34 dB below digital full scale. By default, the test tone output is disabled.

***DISABLE TEST TONE***

F0H 00H 01H 02H 01H 01H 04H F7H

F0H = MIDI System Exclusive Header

00H, 01H, 02H =

System Exclusive Manufacturer ID:

Crystal Semiconductor Corp.

01H = Product ID: CS9236

01H = Model/Version ID: 01

04H = Message Type: Disable Test Mode

F7H = End of System Exclusive flag (EOX)

Receipt of the DISABLE TEST TONE system exclusive message will cause the CS9236 to disable the test tone output (See description of ENABLE TEST TONE). By default, the test tone output is disabled.

## PIN DESCRIPTIONS

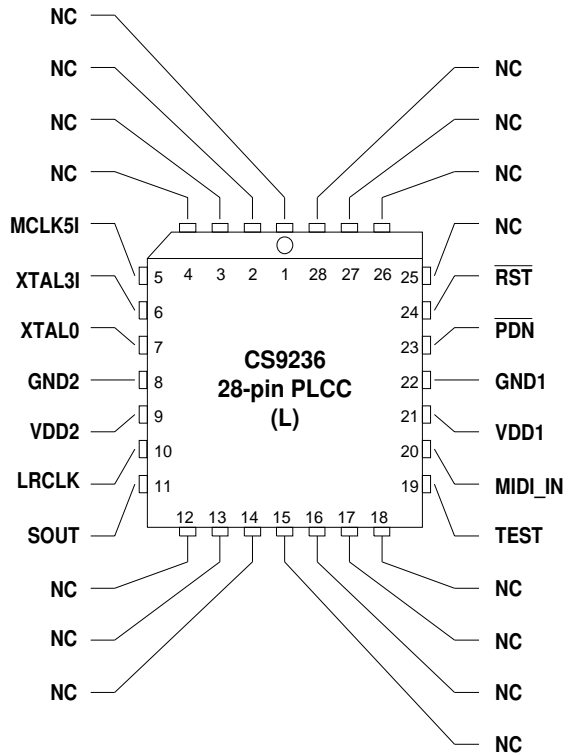
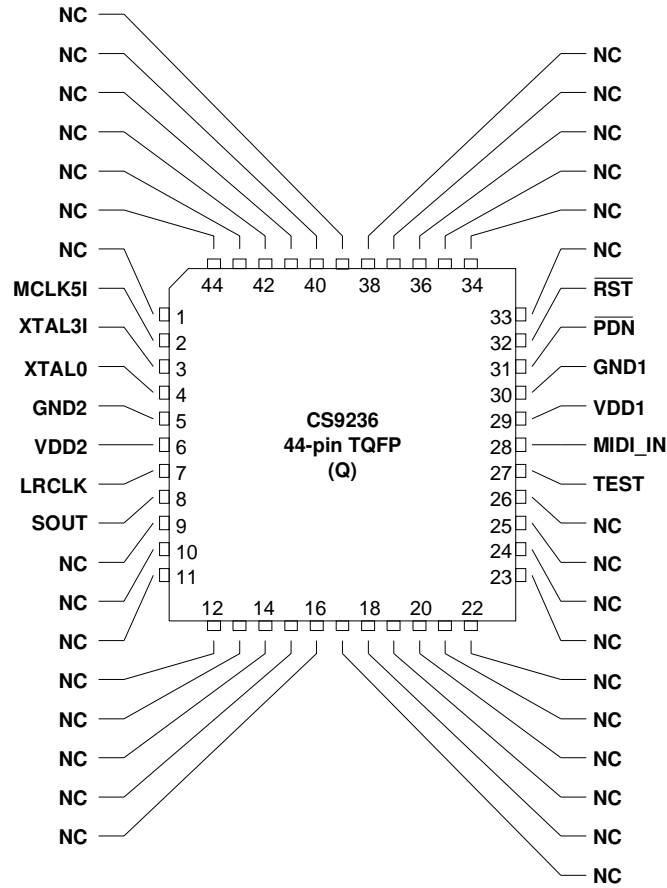

**MIDI\_IN - Serial MIDI Data Input, PIN 20 (L), PIN 28 (Q).**

Serial MIDI data input to the device. This data stream contains MIDI messages which are used to control music synthesis and initiation/termination of the Test Tone.

**SOUT - Serial Audio Data Output, PIN 11 (L), PIN 8 (Q).**

Serial data output stream carrying the stereo digital audio output from the device. The digital audio output sample rate is 44.1 ksample/s, stereo.

**LRCLK - Serial Audio Data Left/Right Clock Output, PIN 10 (L), PIN 7 (Q).**

This is the left/right word clock output associated with the serial data output, SOUT. The LRCLK signal identifies word alignment of the SOUT data stream.

 **$\overline{RST}$  - Reset Input, PIN 24 (L), PIN 32 (Q).**

This active-low input signal is used to initialize all of the devices internal states and registers to a known default state. The  $\overline{RST}$  signal will silence the digital audio output.

 **$\overline{PDN}$  - Power-Down Input, PIN 23 (L), PIN 31 (Q).**

This active-low input signal is used to set the device to the low power consumption Power-Down mode of operation. The Power-Down mode is fully static; all internal states and register values are retained during Power-Down. Deassertion of the  $\overline{PDN}$  signal returns the device to normal operation.

**TEST - Factory Test Input, PIN 19 (L), PIN 27 (Q).**

Used for factory testing of device. This pin must be tied to digital ground during normal operation.

**MCLK5I - 5 Volt Master Clock Input, PIN 5 (L), PIN 2 (Q).**

This is the master clock input for the device. The CS9236 internal timing is derived from one of two possible sources; the part may be supplied a 16.9344 MHz Master Clock signal from an external source, or the timing may be generated using the on-chip oscillator circuit in conjunction with an external 16.9344 MHz quartz crystal. When a Master Clock signal is provided to the CS9236 from an external device, the Master Clock signal should be connected to the CS9236 MCLK5I input pin and the XTAL3I input pin is grounded. When the CS9236 internal timing is generated using the on-chip oscillator circuit, a 16.9344 MHz quartz crystal is connected between the CS9236 XTAL3I input pin and the XTALO output pin, and the MCLK5I input pin is grounded. In this case, the XTALO output may also be used as a 384X master clock for the CS9236 digital audio output signal, SOUT.

**XTAL3I - 3 Volt Crystal Oscillator Input, PIN 6 (L), PIN 3 (Q).**

This is the input pin for the on-chip crystal oscillator circuit. The CS9236 internal timing is derived from one of two possible sources; the part may be supplied a 16.9344 MHz Master Clock signal from an external source, or the timing may be generated using the on-chip oscillator circuit in conjunction with an external 16.9344 MHz quartz crystal. When a Master Clock signal is provided to the CS9236 from an external device, the Master Clock signal should be connected to the CS9236 MCLK5I input pin and the XTAL3I input pin is grounded. When the CS9236 internal timing is generated using the on-chip oscillator circuit, a 16.9344 MHz quartz crystal is connected between the CS9236 XTAL3I input pin and the XTALO output pin, and the MCLK5I input pin is grounded. In this case, the XTALO output may be used as a 384X master clock for the CS9236 digital audio output signal, SOUT.

**XTALO - Crystal Oscillator Output/384X Digital Audio Clock Output, PIN 7 (L), PIN 4 (Q).**

This pin is the output of the on-chip crystal oscillator circuit. This output may also be used as a 384X master clock for the CS9236 digital audio output signal, SOUT. The CS9236 internal timing is derived from one of two possible sources; the part may be supplied a 16.9344 MHz Master Clock signal from an external source, or the timing may be generated using the on-chip oscillator circuit in conjunction with an external 16.9344 MHz quartz crystal. When a Master Clock signal is provided to the CS9236 from an external device, the Master Clock signal should be connected to the CS9236 MCLK5I input pin and the XTAL3I input pin is grounded. When the CS9236 internal timing is generated using the on-chip oscillator circuit, a 16.9344 MHz quartz crystal is connected between the CS9236 XTAL3I input pin and the XTALO output pin, and the MCLK5I input pin is grounded. In this case, the XTALO output may be used as a 384X master clock for the CS9236 digital audio output signal, SOUT.

**VDD1, VDD2 - Digital Supply Voltage, PINS 21 and 9 (L), PINS 29 and 6 (Q), respectively.**

3.3VDC supply voltage connections for the device.

**GND1, GND2 - Digital Ground, PINS 22 and 8 (L), PINS 30 and 5 (Q), respectively.**

0 VDC digital ground connections for the device.

**NC - No Connection, PINS 1-4, 12-18, 25-28 (L), PINS 1, 9-26, 33-44 (Q)**

These pins must be left floating (no connection to external circuitry).



## PACKAGE PARAMETERS

44 PIN TQFP

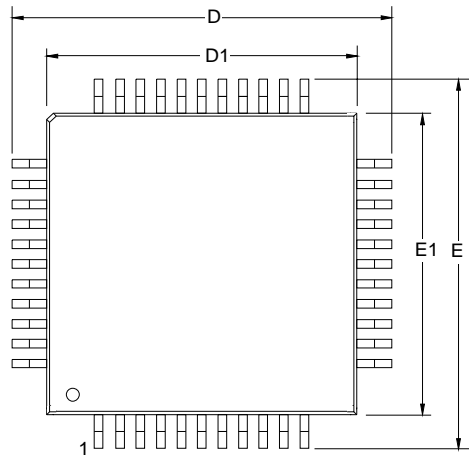

DIM	44 LEAD TQFP					
	MILLIMETERS			INCHES		
	MIN	NOM	MAX	MIN	NOM	MAX
A			1.60			0.063
A1	0.05		0.15	0.002		0.006
A2	1.35	1.40	1.45	0.053	0.055	0.057
b	0.30	0.37	0.45	0.014	0.016	0.018
c	0.09	0.145	0.20	0.004	0.006	0.008
D/E	11.75	12.0	12.25	0.462	0.472	0.482
D1/E1	9.90	10.0	10.10	0.390	0.394	0.398
e	0.70	0.80	0.90	0.026	0.031	0.036
L	0.45	0.60	0.75	0.018	0.024	0.030
∞	0°	3.5°	7°	0°	3.5°	7°
ccc			0.10			0.004

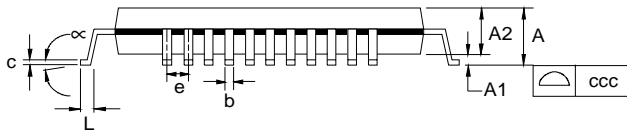

A		B		C	
MIN	MAX	MIN	MAX	MIN	MAX
12.32	12.57	11.43	11.58	9.91	10.92
(0.485)	(0.495)	(0.450)	(0.456)	(0.390)	(0.430)

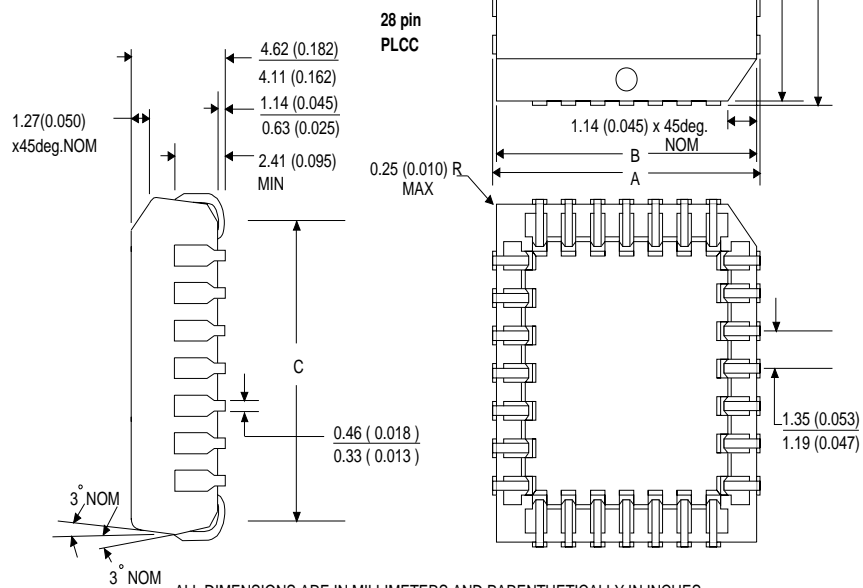
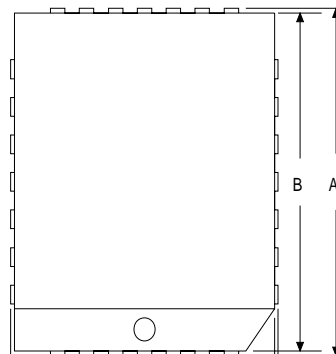

ALL DIMENSIONS ARE IN MILLIMETERS AND PARENTHETICALLY IN INCHES.



Smart *Analog*<sup>TM</sup> is a Trademark of Crystal Semiconductor Corporation